

Cabinets & Accessories

Wall – Mounted Cabinet - Model P



19" Wall-mounted cabinets and racks are a cost-effective solution that is both aesthetically pleasing and durable. Designed to be installed in data centres, equipment rooms and office

Features & Benefits

- Suitable for patch panels
- Top and bottom knock of panel
- Sturdy for fibre and copper panel installation
- 120° Swing door
- Tempered Glass
- Welded structure
- Key locked for security
- Compatible with various 19" accessories

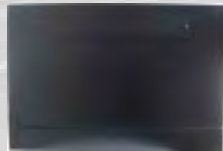

Below we have our standard stock sizes for height, widths and depths, but we also offer custom-built cabinets. If you require a specification which is not specified, then contact us and we can assist you.

Available Configurations

Capacity U	Height(mm)	Widths(mm)	Depths(mm)	Colours
2	100	510	300	Black
3	145	510	300	Black
4	180	510	300	Black
6	280	510	300	Black

Cabinets & Accessories

Wall – Mounted Cabinet - Model P

Technical Specifications

Part	Material	Surface
Top cover	SPCC Cold-Rolled Steel 1.0 mm	Powder coated
Frame	SPCC Cold-Rolled Steel 1.0 mm	Powder coated
Front door	Toughened Glass 5m/SPCC Cold-Rolled Steel 1.2mm	Powder coated
Side panel	SPCC t1.2	Powder coated
Side panel	SPCC Cold-Rolled Steel 1.0 mm	Powder coated
Rail	SPCC Cold-Rolled Steel 1.0 mm	Powder coated
Back panel	SPCC Cold-Rolled Steel 1.0 mm	Powder coated
Bottom	SPCC Cold-Rolled Steel 1.0 mm	Powder coated

Technical Drawings

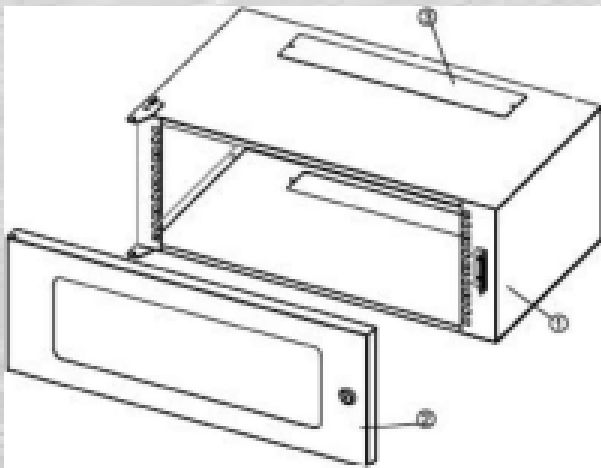

1	Frame
2	Front Door
3	Cable Entry

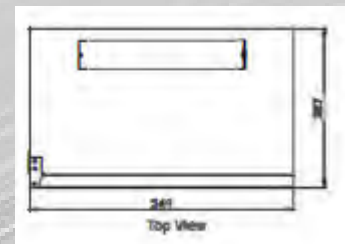
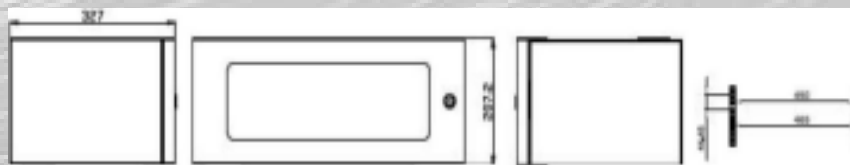

For any queries, please contact Technoline Solutions team using the details below.