

## Cabinets & Accessories

# Wall – Mounted Cabinet - Model Q



Wall-mounted cabinets and racks are a cost-effective solution that is both aesthetically pleasing and durable. Designed to be installed in data centres, equipment rooms and office environments to mount telecommunication, data communication, security, broadcasting and other electronic equipment.

### Features & Benefits

- Available in a variety of heights and depths
- Available in gray or black - more colours available
- Tempered glass 200° swing front door with lock
- Adjustable front and rear mounting rails with U markings
- 600mm wide body
- Quick removable side doors
- Vented top and bottom panels enabling ventilation and reliable operation
- Compatible with various 19" accessories
- Maximum 50kgs UDL loading capacity
- 2x 120mm fan cut-outs
- Strong welded chassis construction, only available ready-built



Below we have our standard stock sizes for height, widths and depths, but we also offer custom-built cabinets. If you require a specification which is not specified, then contact us and we can assist you.

### TECHNICAL SPECIFICATIONS

<b>Build Type</b>	Welded	<b>Assembly</b>	Ready-built
<b>Chassis Material</b>	1.2mm cold-rolled steel	<b>Maximum Load Capacity</b>	50kgs UDL
<b>Front Door Material</b>	5.0mm toughened glass	<b>IP Rating</b>	20
<b>Cable Entries</b>	2 (1x top, 1x bottom)	<b>Mounting Profiles</b>	Front and rear
<b>Lockable Doors</b>	Front	<b>Fan Cut-Outs</b>	2x 120mm

### AVAILABLE CONFIGURATIONS

Capacity (U)	Height (mm)	Widths (mm)	Depths (mm)	Colours
6	310	540	450, 600	Black, Grey
9	445	540	450, 600	Black, Grey
12	580	540	450, 600	Black, Grey
15	710	540	450, 600	Black, Grey

## Technical Drawings

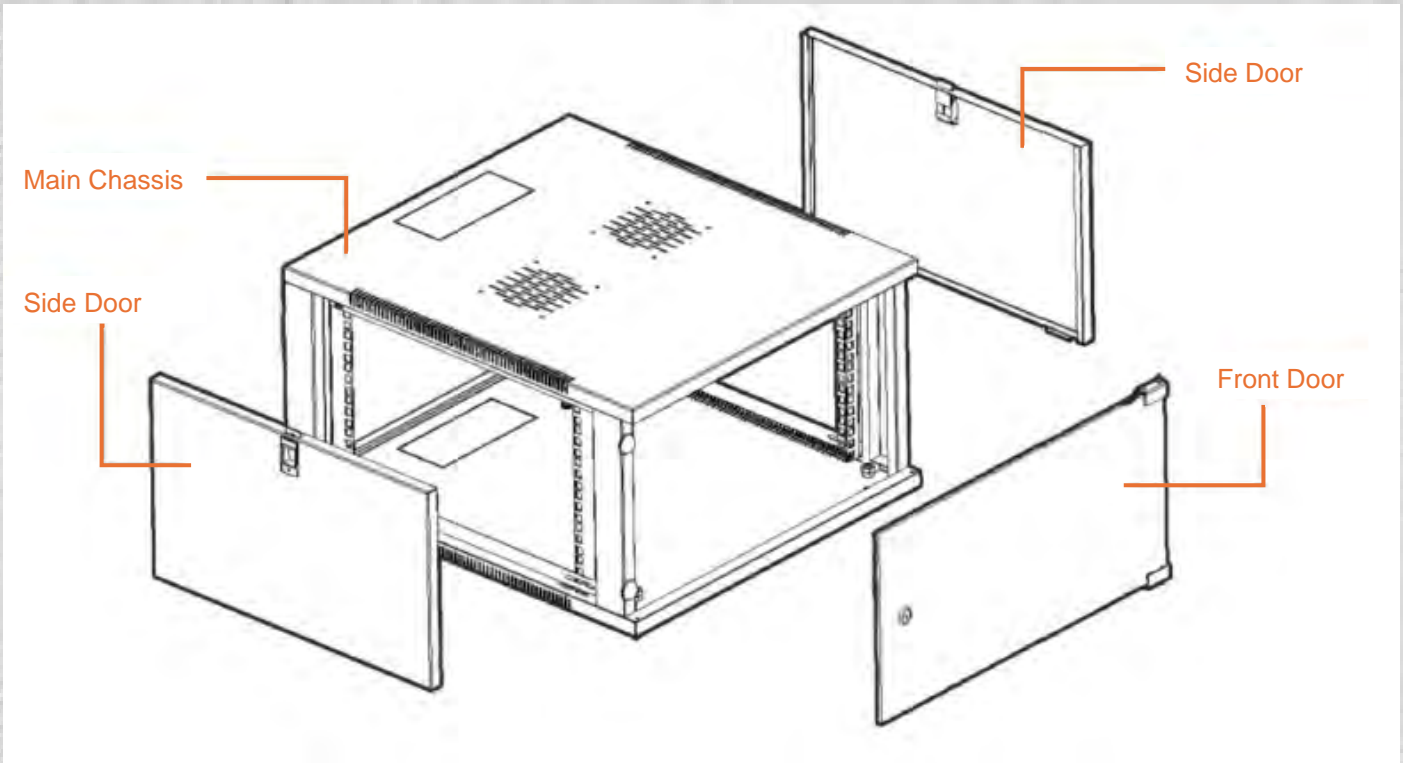

TECHNICAL SPECIFICATIONS		
Part	Material	Surface
Main Chassis	SPCC Cold-Rolled Steel 1.0mm	Powder Coated/Vented Front & Sides
Side Door	SPCC Cold-Rolled Steel 1.0mm	Powder Coated
Front Door	Toughened Glass 5m	

For any queries, please contact Technoline Solutions team using the details below.