

Cabinets & Accessories

Wall – Mounted Cabinet - Model A



Wall-mounted cabinets and racks are a cost-effective solution that is both aesthetically pleasing and durable. Designed to be installed in data centres, equipment rooms and office environments to mount telecommunication, data communication, security, broadcasting and other electronic equipment.

Features & Benefits

- Available in a variety of heights and depths
- Available in gray or black - more colours available
- Tempered glass 200° swing front door with lock
- Feet and castors can be provided for floor-standing option
- Adjustable front and rear mounting rails
- Available ready-built or flat packed 600mm wide body
- Quick release side doors, optional key locks if required
- Tool-free changing of door orientation
- Vented top and bottom panels enabling ventilation and reliable operation
- Compatible with various 19" accessories
- Maximum 60kgs UDL loading capacity



Available Ready-Built



30 Minute Assembly



1 Person Assembly



Available Flat-Packed



60kgs UDL Capacity

Below we have our standard stock sizes for height, widths and depths, but we also offer custom-built cabinets. If you require a specification which is not specified, then contact us and we can assist you.

TECHNICAL SPECIFICATIONS

Build Type	Bolted	Assembly	Ready-built or flat-packed
Chassis Material	1.2mm cold-rolled steel	Maximum Load Capacity	60kgs UDL
Front Door Material	5.0mm toughened glass	IP Rating	20
Cable Entries	2 (1x top, 1x bottom)	Mounting Profiles	Front and rear
Lockable Doors	Front and sides	Fan Cut-Outs	2x 120mm

AVAILABLE CONFIGURATIONS

Capacity (U)	Height (mm)	Widths (mm)	Depths (mm)	Colours
4	285	600	300,450	Black, Grey
6	370	600	300, 450, 600	Black, Grey
9	500	600	300, 450, 600	Black, Grey
12	635	600	300, 450, 600	Black, Grey
15	770	600	300, 450, 600	Black, Grey

Technical Drawings

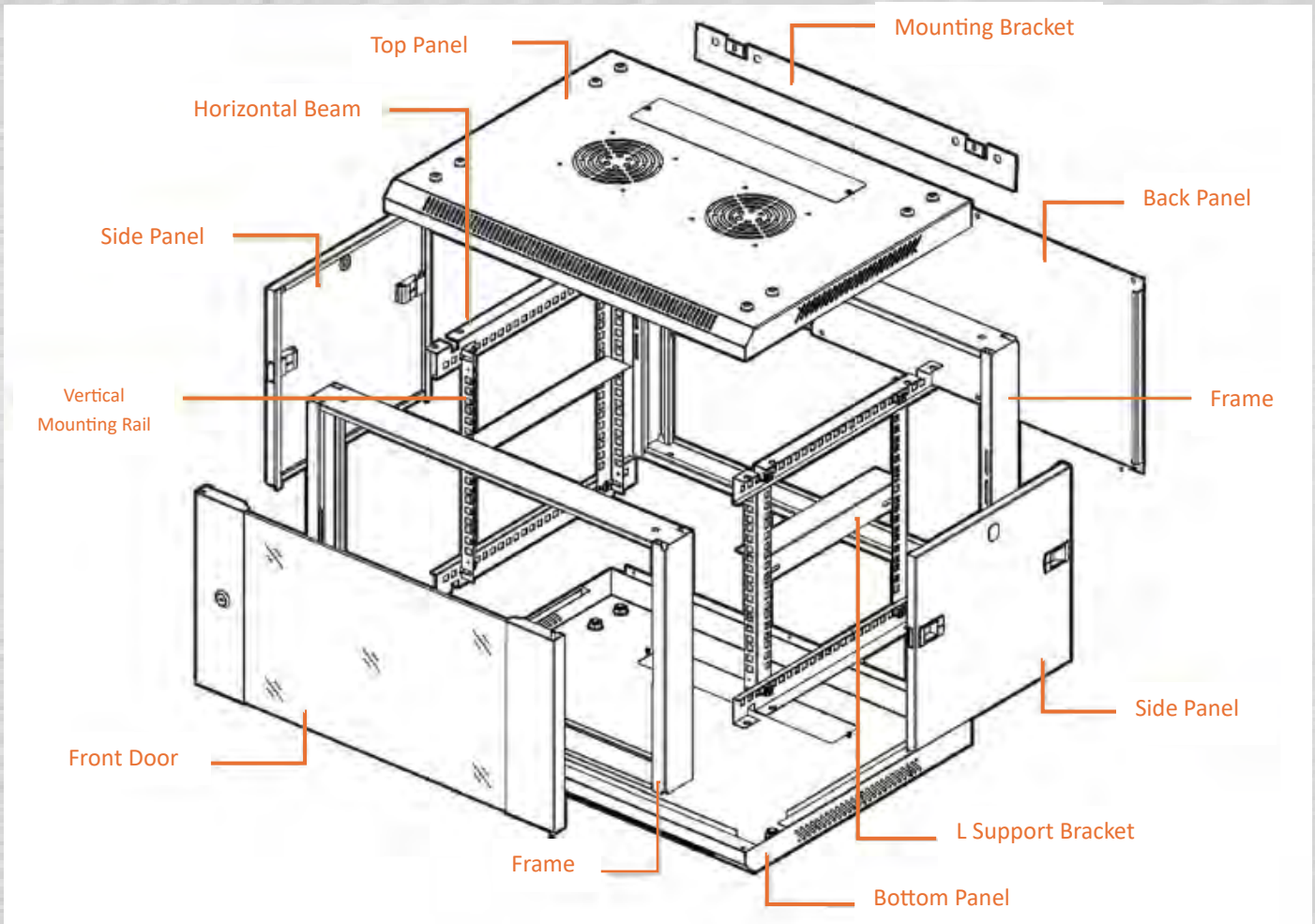

TECHNICAL SPECIFICATIONS		
Part	Material	Surface
Top Panel	SPCC Cold-Rolled Steel 1.0mm	Powder Coated/Vented Front & Sides
Frame	SPCC Cold-Rolled Steel 1.0mm	Powder Coated
Front Door	Toughened Glass 5m/SPCC Cold-Rolled Steel 1.2mm	Powder Coated/Vented Front & Sides
Side Panel	SPCC Cold-Rolled Steel 1.0mm	Powder Coated/Vented (Optional)
Vertical Mounting Rail	SPCC Cold-Rolled Steel 1.2mm	Powder Coated
L Support Bracket	SPCC Cold-Rolled Steel 1.0mm	Powder Coated
Back Panel	SPCC Cold-Rolled Steel 1.2mm	Powder Coated
Horizontal Beam	SPCC Cold-Rolled Steel 1.2mm	Powder Coated
Bottom Panel	SPCC Cold-Rolled Steel 1.0mm	Powder Coated/Vented Front & Sides
Mounting Bracket	SPCC Cold-Rolled Steel 1.0mm	Powder Coated

For any queries, please contact Technoline Solutions team using the details below.